

Best available techniques in the fertilizer production industry: A Review

Ahmet Ozan Gezerman* and Burcu Didem Çorbacıoğlu

Chemical Engineering Department, Yildiz Technical University, 34220, Istanbul, Turkey

* Corresponding author at: Chemical Engineering Department, Yildiz Technical University, 34220, Istanbul, Turkey.
 Tel.: +90.532.6538505. Fax: +90.212.3834725. E-mail address: ahmet.ozan@yahoo.com (A.O. Gezerman).

REVIEW INFORMATION



DOI: 10.5155/eurjchem.7.2.243-247.1411

Received: 11 February 2016

Received in revised form: 12 March 2016

Accepted: 21 March 2016

Published online: 30 June 2016

Printed: 30 June 2016

KEYWORDS

Urea
 Fertilizer
 Ammonia
 Nitric acid
 Ammonium nitrate
 Best available techniques

ABSTRACT

Treatment and disposal of emission gases used for fertilizer production are among the most pressing issues in the modern fertilizer industries. Associations such as the European Manufacturer Association are developing new techniques, i.e., best available techniques, to resolve such problems. Best available techniques have been developed by the European Manufacturer Association to standardize the solutions to common problems encountered in the fertilizer industry, such as optimization of pH, pressure, temperature, nitrogen content, and fertilizer particle size. The best available techniques aim at minimizing greenhouse gas emissions in the fertilizer industry as well as wastewater treatment and waste management. The high operation and investment costs in the fertilizer industry have prompted manufacturers to consider the application of the best available techniques.

Cite this: *Eur. J. Chem.* 2016, 7(2), 243-247

1. Introduction

The fertilizer industry relies on the use of ammonia, nitric acid, sulfuric acid, and phosphoric acid for fertilizer production. Best available techniques (BATs) are not restricted to fertilizer production but can be applied to sulfuric acid, nitric acid, and phosphoric acid production as well. The BAT aims at optimal utilization of ammonia, hydrogen fluoride, hydrofluoric acid, phosphoric acid, nitric acid, sulfuric acid, phosphorous, nitrogen, and potassium in fertilizer production [1]. The nutrient content of fertilizers is expressed as nitrogen (N), phosphate (P₂O₅), and potash (K₂O), as well as elemental phosphorus (P) and potassium (K) [2].

The sulfur content is expressed as sulfate in products containing large amounts of ammonium sulfate and superphosphate [3]. Secondary raw materials such as calcium, magnesium, sodium, and sulfur, which are formed when the primary raw materials are subjected to mechanical treatments such as grinding, can contaminate the fertilizers [4]. Basic fertilizers contain micronutrients such as boron, cobalt, copper, iron, manganese, zinc, and molybdenum; alternatively, special fertilizers containing these micronutrients are commercially available. About 97% of the nitrogenous fertilizers are manufactured using ammonia, and 70% of the phosphatic fertilizers are manufactured from phosphoric acid [2].

The most important chemicals used for manufacturing fertilizers are NH₃, HNO₃, H₂SO₄, and H₃PO₄; these chemicals are used in detergent, metal plating, surfactant, and pharmaceutical industries as well. However, processes involving the use of HF are not compatible with fertilizer production [3]. Figure 1 outlines the general process for manufacturing nitrogenous or phosphatic fertilizers in the large volume inorganic chemicals (LVIC)-ammonia, acids, and fertilizers (AAF) industries [4].

2. Materials and methods

Figure 1 shows the flow diagrams for the production of fertilizers and acids. Dilution stages, air and water addition, and energy production are involved in sulfuric acid, phosphoric acid, hydrofluoric acid, ammonium nitrate (AN), calcium ammonium nitrate (CAN), nitrogen-phosphate-potassium (NPK) fertilizer production; the application of BAT to these processes is investigated.

In this study, we focus on the contact process for the manufacture of sulfuric acid, which involves the use of H₂O and SO₂. Phosphoric acid is produced by the wet process, via the reaction between fluorapatite, or phosphate rock, and sulfuric acid. Hydrofluoric acid in this study is obtained from the reaction between calcium fluoride and sulfuric acid. Ammonium nitrate is produced via the reaction between gasified anhydrous ammonia and nitric acid.

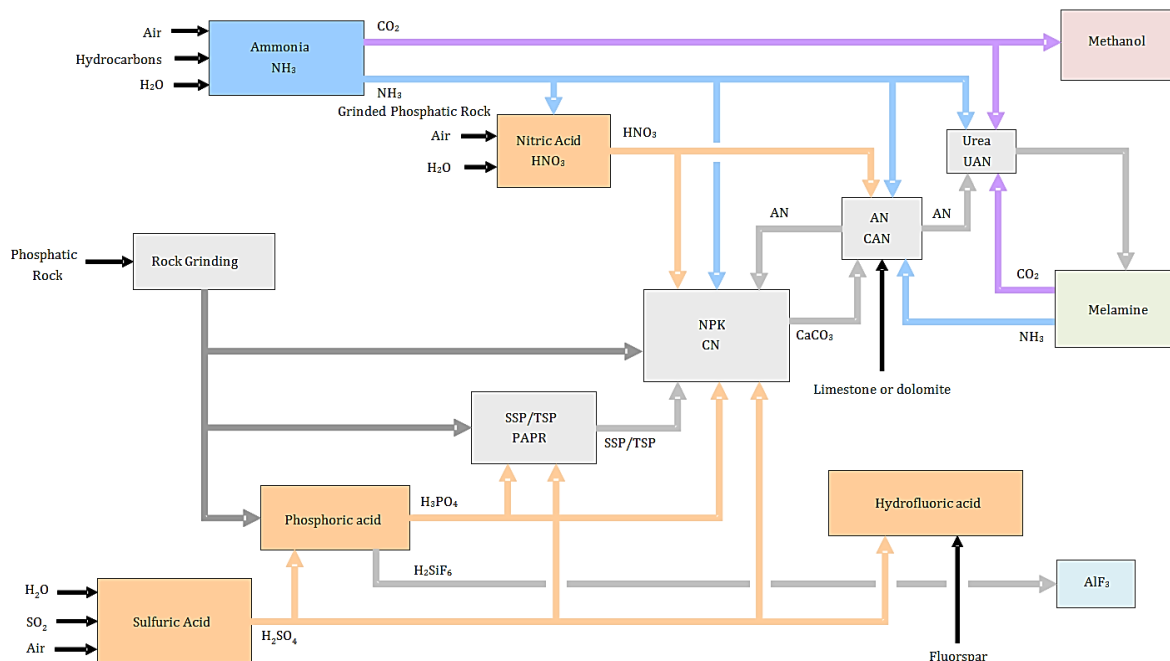

Figure 1. General information on processes employed in large volume inorganic chemicals (LVIC)-ammonia, acids, and fertilizers (AAF) industries.

A water-soluble version of calcium ammonium nitrate, which is subjected to the BAT strategy, is produced by mixing ammonium nitrate with calcium carbonate. NPK fertilizer is produced by the mixed acid process with phosphate rock digestion. Urea is produced using ammonia, carbon dioxide, and formaldehyde.

3. Results and discussion

3.1. Production and environmental problems

Typically, LVIC-AAF production requires special methods and sophisticated equipment. However, NPK, AN/CAN, and phosphatic fertilizers are produced using the same equipment lines [5], and the production capacity ranges from 100 to 3000 tons per day. Nitrogenous fertilizer plants consume a large amount of energy because of the power supply required for the heating lines, compressors, and pumps [6].

In general, an electrical motor is sufficient for the functioning of small-size equipment, while steam turbines are needed for large equipment. Electrical energy is supplied by government facilities or is produced in power plants. Steam is produced by a steam generation plant or co-generation plant, or from the energy released in the production of ammonia, nitric acid, and sulfuric acid [7].

About 2-3% of the global energy is consumed by the fertilizer production [8]. In particular, Western Europe is the main contributor to the fertilizer industry. Among the various types of fertilizers, nitrogenous fertilizers require the maximum energy [9], for preparation of the raw materials, i.e., nitrogen fixation. A significant part of the energy is required to convert nitrogen to urea [10]. In the LVIC-AAF industries, high-, moderate-, or low-pressure steam/hot water is commonly generated during sulfuric acid and nitric acid production [10].

Large amounts of NO_x , SO_2 , HF, NH_3 , and particulate matter, which are common air pollutants, are generated in large volumes from fertilizer plants. During the production of HNO_3 , N_2O , which is a greenhouse gas, is produced in

significant amounts [11]. Some byproducts such as phosphogypsum are also formed in notable high amounts. In the fertilizer industry, byproducts such as phosphogypsum are often generated in large quantities. These byproducts have potential application in cements, detergents, etc. However, the high transportation and handling costs prevent the reuse of these materials in other industries, thereby necessitating their disposal [1].

3.2. Best available techniques (BAT)

The BAT aims at conducting regular energy audits in all production plants, monitoring the key performance parameters, and maintaining the mass balance of nitrogen, P_2O_5 , steam, water, and CO_2 . Energy losses are generally minimized by preventing reduction in the steam pressure or by avoiding excessive steam production with the help of an all-steam system. Excessive thermal energy should be used in the operation, but if local factors do not allow for this, steam should be used for producing electrical power [12].

Aim in BAT, with recycling of mass flows or a combination of redirection operation, effective equipment usage, by pre-heating of combustion air, by saving effective of heat exchanger, by decreasing heat integration, to minimize waste water by recycling of process waters, by applying developed control systems and to increase environmental performance of maintenance and production facilities [3].

3.3. Ammonia production

As per the BAT for new plants, a conventional converter, a reduced primary converter, or an auto-thermal heat exchanger is to be used. To achieve the NO_x emission levels shown in the Table 1, it is necessary to use a low NO_x burner in the primary converter, as in the selective non-catalytic reduction (SNCR) technique, for the removal of ammonia from flue gas and waste gases; alternatively, an auto-thermal heat exchanger for low-temperature desulfurization should be applied [13].

Table 1. BAT for mitigating NO_x concentrations in ammonia production [4] *.

Factory concepts	NO _x emission as NO ₂ (mg/Nm ³)
Developed a conventional process and a primary converter process	90-230
Autothermal converter with a heat exchanger	
Process air heater	80
Secondary steam drum	20

* A linear relation between the concentration levels and emission factors was not established. The maximum allowable limit for ammonia emission in phosphoric acid production is 0.29-0.32 kg/tonne NH₃. This range is used as the reference in the primary converter. For the auto-thermal converter, 0.175 kg/tonne NH₃ is a necessary criterion.

Table 2. Energy consumption levels in ammonia production [4].

Plant concept	Net energy consumption GJ(LHV)/tonne NH ₃
Primary conventional converter process or autothermal converter	27.6-31.8

Table 3. N₂O levels in HNO₃ production with BAT application [4] *.

Process type	Plant type	N ₂ O emission level	
		kg/tonne 100 % HNO ₃	ppmv
M/M, M/H and H/H	New facilities	0.12-0.60	20-100
	Present facilities	0.12-1.85	20-300
L/M Factories		No result	

* In fertilizer and acid production processes, four different pressure stages can be applied. (M/M: Mono Medium/Medium, applied pressure 1.7-6.5 bar; M/H: Dual Medium/High, applied pressure 1.7-13.0 bar; H/H: Mono High/High, applied pressure 6.5-13.0 bar; L/M Dual Low/Medium, <1.7 bar)

Table 4. NO_x emission levels for HNO₃ production by applying BAT [4].

Plant type	NO _x emission level as NO ₂	
	kg/tonne 100 % HNO ₃	ppmv
New facilities	-	5-75
Present facilities	-	5-90
NH ₃ derived from Nitric acid production	-	<5

Table 5. SO₂ emission levels and conversion rates after applying BAT for H₂SO₄ production [4].

Conversion process	Plant type	Daily average	
		Conversion ratio	SO ₂ (mg/Nm ³)
Burning of sulfur, two-stage absorption	Present facilities	99.8-99.92 %	30-680
	New facilities	99.9-99.92 %	30-340
Two-stage contact		99.7-99.92 %	200-680
One contact /one absorption			100-450
Other			15-170

The BAT aims at reducing energy consumption and mitigating energy loss. The BAT for obtaining the energy consumption levels shown in Table 2 involves increasing the preheating time for the raw material, preheating of the combustion air, and modifying the process equipment. The other options involve removal of excessive CO₂, removal of SO₂ at low temperatures, use of small catalyst particles in the ammonia converter, use of a catalyst in low-pressure ammonia synthesis, liquid nitrogen washing for the removal of synthesis gases, indirect cooling of the ammonia synthesis reactor, hydrogen recovery from the liquidated gas in ammonia synthesis, or application of a well-developed process control system. To achieve the desired low emission levels in oil and gas refineries, partial oxidation of sulfur and recovery of sulfur from tail gases are recommended as the BAT. Another BAT is the removal of NH₃ from process condensers by stripping. NH₃ is recovered from flare gases in a closed-loop system [14].

3.4. Nitric acid production

The BAT for nitric acid production involves the use of recoverable energy, i.e., steam and/or electrical power generated by common operations. As per the BAT, the following strategies can help reduce greenhouse gas emissions and bring the emission levels close to those mentioned in Table 3 [15]:

- Optimized conditions for raw material preparation
- Optimal mixing of raw materials
- Optimal gas distribution on the catalyst surface
- Monitoring catalyst performance
- Optimization of NH₃/air ratio
- Optimization of pressure and temperature for oxidation

- N₂O separation by expansion of the reactor in new facilities
- Reduction of NO_x and N₂O in tail gases

Different suggestions for BAT application have been provided by the European Fertilizer Manufacturer Association (EFMA), for decreasing N₂O emission levels. Accordingly, a De-N₂O (decreasing N₂O) reactor with the V₂O₅ catalyst is developed. The emission level depends on the lifetime of the catalyst (2.5 kg N₂O/ton 100% HNO₃) in the De-N₂O reactor.

The main goal of the BAT is to decrease pollutant emission under the start and shut conditions. In the BAT, one or more of the strategies below would be applied to decrease NO_x emission levels and obtain the results given in Table 4.

- Optimization of HNO₂ absorption by water during nitric acid production.
- Decreasing NO_x and N₂O concentrations in tail gases
- Addition of H₂O₂ to water to achieve 100% HNO₂ absorption

3.5. Sulfuric acid production

As per the BAT, the SO₂ concentration must be closely monitored for determining the SO₂ emission level and SO₂ conversion rate (Table 5). The suggested strategies for achieving the desired SO₃/H₂SO₄ emission levels (Table 6) involve mitigating the impurity content of the raw materials, using low sulfur concentrations (during sulfur burning), and drying of the gas entrance tubes, use of a large area of the reactor for concentration processing, use of high acid distribution and circulation rates, application of a high-performance filter after SO₂ absorption in sulfuric acid production, and monitoring of absorber acid concentration and temperature.

Table 6. SO₃/H₂SO₄ emission levels in H₂SO₄ production after applying BAT [4].

Process type	Emission levels as H ₂ SO ₄
Whole processes	10-35 mg/Nm ³

Table 7. Achievable consumption levels after applying BAT for HF production [4] *.

Fuel consumption levels	GJ/tonne HF	Details
Fuel for heating	4.0-6.8	Present facilities
	4.0-5.0	New facilities, anhydrous HF production
	4.5-6.0	New facilities, anhydrous HF production, HF solution production

* The BAT for the fluorspar process is to apply a combination of the following techniques and achieve fuel consumption levels within the ranges.

Table 8. Achievable emission levels in HF production by applying BAT [4].

Type of tail gasses	kg/tonne HF	mg/Nm ³	Details
SO ₂	0.001-0.010		Annual average
Fluorides as HF		0.6-5.0	

Table 9. Air emission levels upon applying BAT for NPK fertilizer production [4].

Process type	Parameter	Concentration(mg/Nm ³)	Removal efficiency, %
Grinding phosphate rock, washing sand	NO _x as NO ₂	100-425	
	Fluoride as HF	0.3-5.0	
Neutralization, granulation, drying, plating of fertilizer particle surface with plating oil or an organic plating material containing amines, cooling.	NH ₃	5-30	
	Fluoride as HF	1-5	
	Dust	10-25	>80
	HCl	4-23	

The aim of the BAT is to decrease or mitigate NO_x emissions by reusing the exhaust gasses during H₂SO₄ production.

3.6. Phosphate rock grinding and prevention of rock dust dispersion

The BAT involves decreasing dust emissions during phosphate rock grinding by using a ceramic filter, in order to achieve a dust emission level of 2.5-10 mg/Nm³. In addition, prevention of phosphate rock dust distributions, and cleaning of conveyors and closed storage/facility areas.

3.7. Phosphoric acid production

The aim of BAT is to obtain a P₂O₅ conversion efficiency of 94 to 98.5% by applying techniques below.

- Dehydration
- Increasing the retention time
- Re-crystallization
- Optimal choice of phosphate rock
- Two-stage filtration
- Recycling water from phosphogypsum bulk

The BAT for phosphate fertilizer production involves minimizing fluoride emission by using a stripping solution, to obtain a fluoride emission level of 1-5 mg/Nm³ fluoride expressed as HF. The BAT for this process is to sell the phosphogypsum or dispose of the phosphogypsum in a proper manner. One of the aims of the BAT is the efficient disposal of wastes such as phosphogypsum. Nonetheless, recovery of phosphogypsum from stacks by various methods such as decomposition is desired, so that it can be used as the raw material in other industries. Fluoride emission in water is to be prevented, and efficient wastewater treatment must be carried out by applying the techniques below.

- Neutralization with limestone
- Filtration and optional sedimentation
- Recycling of phosphogypsum stacks

3.8. Hydrofluoric acid

The options for obtaining the fuel consumption levels given in Table 7 include preheating H₂SO₄, checking the oven temperature regularly, and optimization of oven design, use of a pre-reactor system, oven heating, and energy recovery.

The BAT for treating the tail gases in calcium fluoride production involves wastewater treatment for obtaining the emission levels given in Table 8. The aim is to achieve a dust emission level of 3-19 mg/Nm³ during storage and transfer.

Since frequent replacement of filters is not economical, the dust emission levels recommended by the BAT could not be obtained. Wastewater from the stripping process in H₂SO₄ production can be treated by neutralization, coagulation, and filtration processes. The BAT involves disposal of anhydride and fluorosilicic acid, which are waste products of the phosphate fertilizer industry.

3.9. NPK fertilizer production

The BAT suggested by EFMA for improving the NPK fertilizer production process involves minimizing emission during granulation by (i) recycling hot air generated in the plant and (ii) recovering the outlier particles that fall beyond the range of particles sizes required for the granulation process. NO_x gas emission during phosphate rock grinding can be minimized by controlling the process parameters such as selection of phosphate rock and rock/acid ratio.

Emission in air emission can be decreased by applying multi-stage stripping to the sand washing and grinding processes for phosphate rock, so that the emission levels given in Table 9 are achieved. The following techniques can be incorporated during neutralization, cooling, coating, and drying: Dust removal by using cyclones and/or filters, wet stripping and minimizing volume of wastewater

3.10. Urea production

The BAT for urea production involves increasing the environmental performance of the process by establishing a system for monitoring and measuring size distribution, selecting a suitable grinder, and incorporating an in-row cooling system [5]. The energy consumption can be optimized by applying the techniques below:

- Adding a recycling stripping system for new plants
- Using a higher-efficiency stripping system for increasing the capacity of conventional recycling plants
- Heat integration for the stripping system
- Combination of evaporation and condensation technologies

Table 10. Urea production and BAT levels for wastewater treatment [4].

Process type	Plant type	NH ₃ (ppm, w/w)	Urea (ppm, w/w)
After process water treatment	New plant	1	1
	Present plant	<10	<5

Table 11. Emission levels in air with BAT application to SSP/TSP production [4].

Process type	Parameter	Concentration mg/Nm ³	Removal efficiency, %
Neutralization, granulation, drying, coating, cooling	NH ₃	5-30	> 80
	Fluoride as HF	1-5	
	Dust	10-25	
	HCl	4-23	

All exhaust gases must be treated by considering their lower explosive limit and by using the stripping method. The stripping solution must be reused, the working conditions in the prilling tower must be optimized, and dust and ammonia emission must be mitigated to obtain an ammonia emission level of 3-35 mg/Nm³. Dust emission levels of 15-55 mg/Nm³ can be obtained by employing the optimized stripping method.

To obtain the values given in Table 10, process water must be treated by desorption and hydrolyzation. If this is not possible, a biological wastewater treatment system can be used.

3.11. AN/CAN production

The BAT for optimization during neutralization/evaporation involves using the reaction heat for evaporation of excessive water.

The BAT involves monitoring the pH, process flow, and temperature. The options for increasing environmental performance are the use of plate-row cooling products, hot air recovery, optimal grinder selection, and measurement of prill size distribution. The dust emission must be minimized to 10 mg/Nm³. Till date, no perfect results have been achieved for air emission by neutralization, evaporation, granulation, prilling, drying, and cooling. The BAT involves recovery of process water and the use of a biological treatment system for wastewater.

3.12. Single super phosphate (SSP)/triple superphosphate (TSP) production

The BAT for SSP/TSP production, with the aim of increasing environmental performance, is to use the processes below during surface finishing:

- Application of plate row cooling products
- Recycling of hot air
- Selection of appropriate grinding conditions
- Measurement of product size distribution for monitoring granulation recycling

The BAT involves decreasing fluoride emissions by using stripping solutions, so that emission levels of 0.5-5 mg/Nm³ are achieved. The stripping operation must be carried out to minimize the amount of recycling water in SSP and TSP production. Emission in air during granulation, neutralization, and cooling must be mitigated to achieve the results outlined in Table 11.

- Cyclones and filters
- Wet stripping

European Union supports R&D projects of waste water treatment and recycling technologies. These projects as potential can be contributed in fertilizer industry.

4. Conclusion

In this study, best available techniques established by the European Fertilizer Manufacturer Association for the production of sulfuric acid, nitric acid, phosphoric acid,

ammonium nitrate, calcium ammonium nitrate, urea, and NPK fertilizers are evaluated, and contributions to producers are discussed. Accordingly, the use of BATs for each of the aforementioned chemicals is desirable, despite concerns regarding the increased production and investment costs that would be incurred.

Acknowledgements

The author would like to thank Deniz Soyuöz for technically supporting the project and for supplying some useful data.

References

- [1]. McGinnis, R. L.; Menachem, E. *Desalination* **2007**, *207*, 370-382.
- [2]. Kongshaug, G. Energy consumption and greenhouse gas emissions in fertilizer production. IFA Technical Conference, Marrakech, Morocco, Vol. 28., 1999.
- [3]. European Fertilizers Manufacturers' Association. Best Available Techniques for Pollution Prevention and Control in the European Fertilizer Industry-Booklet No. 2 of 8: Production of Nitric Acid. European Fertilizers Manufacturers' Association, 1995.
- [4]. Prevention, Integrated Pollution, Control Reference Document on Best Available Techniques for the Manufacture of Large Volume Inorganic Chemicals-Ammonia. Acids and Fertilizers, dated August, 2007.
- [5]. Dahl, O.; Nurmesniemi, H.; Poykio, R.; Watkins, G. *Fuel Process Technol.* **2010**, *91*, 1634-1639.
- [6]. Kai, P.; Pedersen, P.; Jensen, J. E.; Hansen, M. N.; Sommer, S. G. *Eur. J. Agron.* **2008**, *28*, 148-154.
- [7]. Goodrich, J. A.; Lykins, B. W.; Clark, R. M. *J. Environ. Qual.* **1991**, *20*, 707-717.
- [8]. Nayak, P. S.; Singh, B. K. *Desalination* **2007**, *207*, 71-79.
- [9]. Zhang, X. D.; Wang, X. L.; Liu, J. J.; Ren, Z. D. *Process Equip. Piping* **2012**, *4*, 015.
- [10]. Myat, A.; Thu, K.; Kim, Y. D.; Saha, B. B.; Ng, K. C. *Energy* **2012**, *46*, 493-521.
- [11]. Saleh, S. N.; Barghi, S. *Chem. Eng. Res. Des.* **2016**, *109*, 171-179
- [12]. Felten, D.; Fröba, N.; Fries, J.; Emmerling, C. *Renew. Energ.* **2013**, *55*, 160-174.
- [13]. Olsen, R. A. *Fertilizer Technology and Use*. Soil Science Society of America, Inc, Madison, WI, 1971.
- [14]. Gezerman, A. O.; Corbacioglu, B. D. *Int. J. Mod. Chem.* **2012**, *3*, 108-113.
- [15]. Gezerman, A. O.; Corbacioglu, B. D.; Cevik, H. *Int. J. Chem.* **2011**, *3*, 201-209.